

**Panasonic**

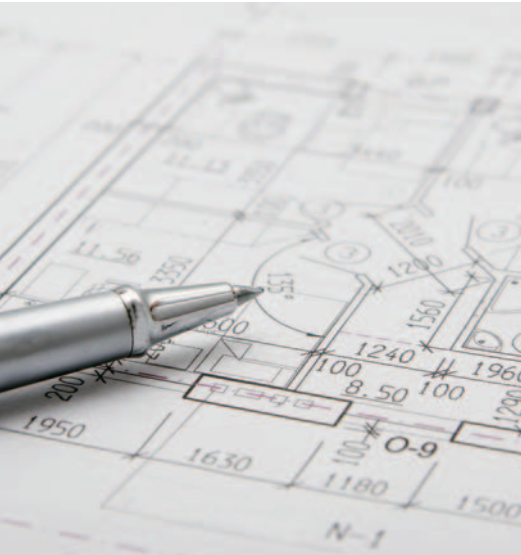

# FS MULTI

AIR CONDITIONING SYSTEM



# Panasonic air conditioning designed to care for you

With more than 50 years of experience, exporting to more than 120 countries around the world, Panasonic is unquestionably one of the leaders in the air conditioning sector. With more than 200 million compressors produced, you are assured of the high quality of Panasonic's air conditioners.



## Japan Design and Global Operations

The FS Multi (Mini-VRF) was designed at the Panasonic Air-Conditioning Division Headquarters in Japan.

A diverse network of production and R&D facilities, Panasonic delivers innovative products incorporating cutting-edge technologies that set the standard for air conditioners worldwide. As a global business continuing to provide truly international products, Panasonic's activities transcend borders.

## Environmentally Conscious

### RoHS Directive Compatible

The RoHS Directive came into force in July 2006. The Directive prohibits the launching of new electrical and electronic equipment in which levels of lead, cadmium, mercury, hexavalent chromium and polybromobiphenyl [PBB] and polybromodiphenyl ether [PBDE] type flame retardants exceed those permitted. All Panasonic's VRF products comply with this European regulation.

### Reducing CO2 Emissions

The Panasonic Group set out a plan to reduce CO2 emissions at production sites worldwide by 300,000 tons by fiscal 2009.

In line with this goal, the Panasonic Air-Conditioning Division Factories established a program forecast to reduce total CO2 emissions by 18% in fiscal 2009 (compared to fiscal 2005).

Through improved manufacturing efficiency, the introduction of design and processing innovations and a wide range of other measures, we are moving ahead to achieve more efficient use of energy.



## Advanced Inverter Technology- Less Energy and More Comfort



By finely controlling compressor rotation to match the room temperature and conditions of use, inverter technology maximizes the motor performance. Panasonic's advanced inverter technology provides fine control over a wide range of rotation speeds to assure exceptionally efficient operation and comfort.

### How can an inverter save energy?

The inverter constantly adjusts compressor rotation speed to provide optimum performance at all times. This extremely precise operation enables quick cooling and heating while reducing power consumption.

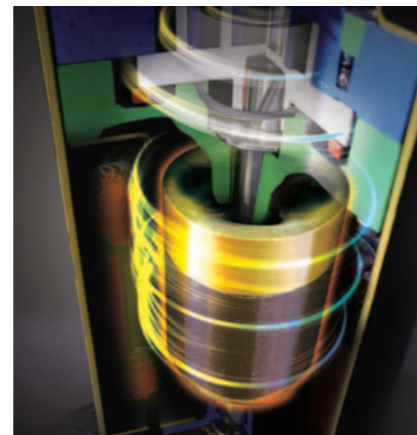

### The key lies in the inverter's smart control

Non-inverter models always operate at a fixed power level before stopping when the cooling or heating load is reached and then restarting a little later. This simple operation results in a lot of wasted energy. By comparison, after reaching the required load, an inverter air conditioner continues operating with minimum power to avoid unnecessary electricity consumption.

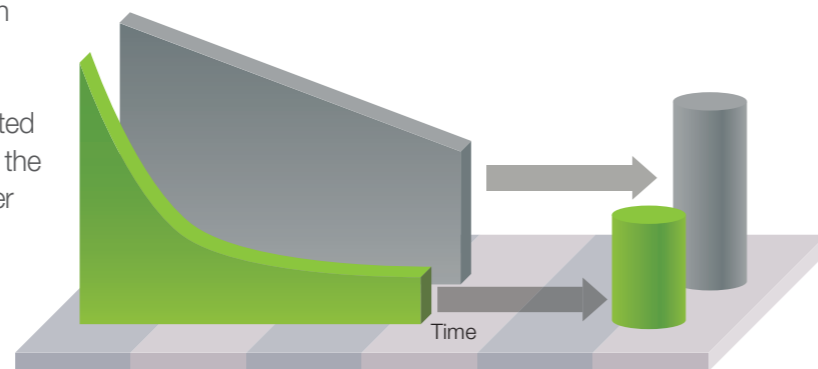

Electricity Consumption Comparison

## VRF Air Conditioning

The FS Multi is a variable refrigerant flow (VRF) system that uses a single outdoor unit to independently control multiple indoor units. By communicating with the indoor units, the outdoor unit controls the flow of refrigerant to each one of them to match their cooling or heating loads. This enables independent operation of each of the indoor units, with inverter control providing optimum energy-saving operation. Air conditioning in multiple rooms by a single outdoor unit also means much less construction and a big improvement in the appearance of buildings. And a wide range of indoor models is available to satisfy the needs of different kinds of buildings.

Taking advantage of its extensive experience with models for both the home and commercial facilities, Panasonic is ready to provide the ideal air conditioning solution.



# FS MULTIVRF

## FS Multi Advantages

FS Multi's cutting edge VRF technology is perfectly suited to small or medium-sized areas, with single-phase power sources, together with advanced Inverter technology, opening up previously unimagined possibilities in the world of air conditioning. Air conditioned spaces can now take on a new dimension. If you have bought a new property, residence, offices or commercial space which is still in the construction phase, or if you are refurbishing, Panasonic offers you the chance to enjoy FS Multi air conditioning.

- Total freedom of choice. Up to 26 different indoor unit models. Allows you to choose the best option depending on architectural needs and decoration criteria.
- Three outdoor unit ratings: (11.2, 14.0, 15.5kW / 38,000, 48,000 and 53,000 Btu), single-phase.
- Inverter technology with R410A refrigerant, "greater comfort and economy with lower power consumption".
- Greatest space reduction. A single outdoor unit feeds up to 8 indoor units (14kW and 15.5kW models).
- Ease of installation. Thanks to the reduced dimensions of the outdoor unit it can be taken to the roof of the building in the lift.

### System Example

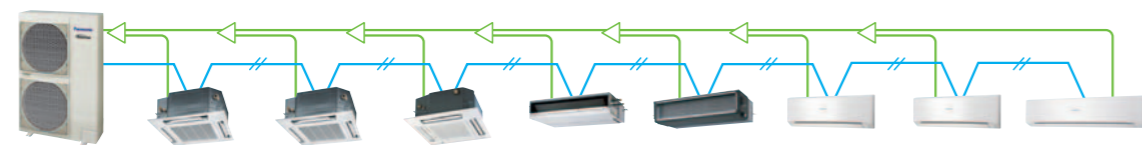

System / kW	11.2	14	15.5
Connectable Indoor Unit	6	8	8

← Refrigerant pipe  
— URBAN net control line



### High-story Apartments

Enabling air conditioning in multiple rooms with a single outdoor unit, the FS Multi system offers an effective solution to today's demand for aesthetically pleasing apartments. The indoor units are also available in various designs providing an ideal match for modern living environments.



### Homes

Since a layout using long piping is possible, a single outdoor unit can be used even for multi-story residences. And there's a range of indoor unit designs to choose from to complement different interiors.



### Offices, Shops and Boutiques

As well as being ideal for new buildings, the FS Multi system offers space-saving benefits when refurbishing and renovating existing spaces. What's more, independent air conditioning reduces energy wasted in unused offices, and much neater pipe layout is possible than with a single split system. Using the Weekly Timer also enables setting for the optimum energy-saving operation in offices and commercial facilities. And there are options enabling digital connection compatibility to meet the needs of business applications.

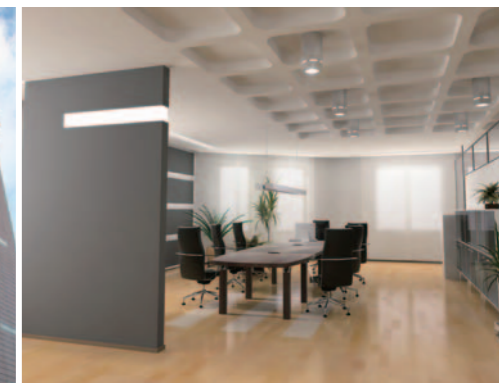

# SYSTEM ADVANTAGES

# FS MULTI

The FS Multi system solves the air conditioning design and construction problems that arise due to pipes at different heights and the location of the installation site. Exceptional installation flexibility makes installation easy and maintains the attractive appearance of buildings.

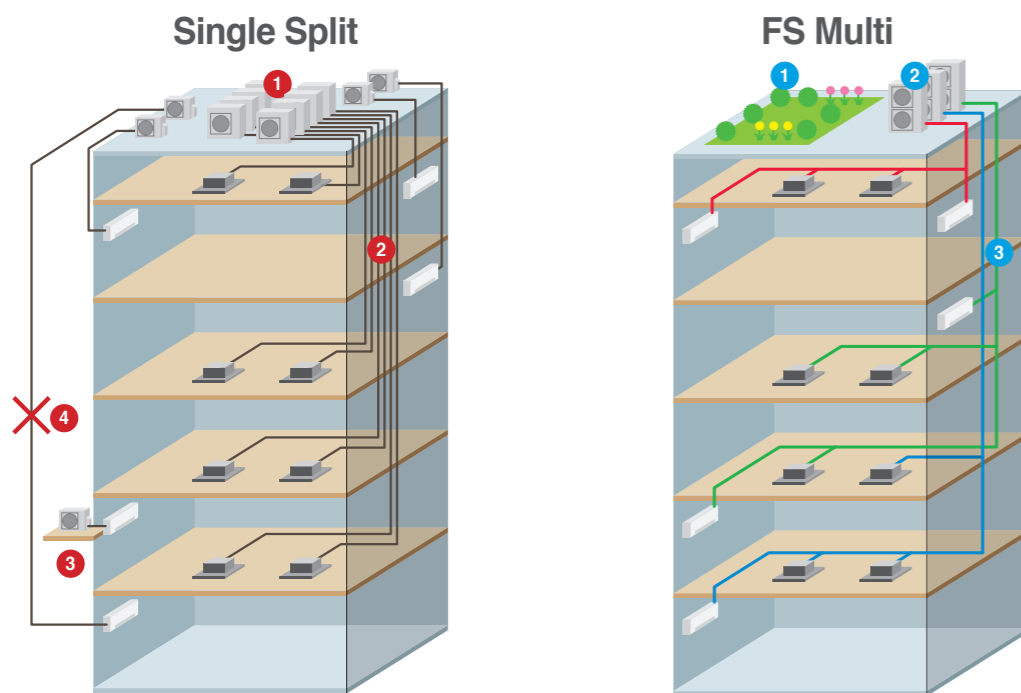

### Frequent Single Split System Problems

- 1 Requires many outdoor units and large installation space. So it spoils the building's appearance, and the building's strength must be assessed.
- 2 Requires many pipe shafts.
- 3 Pipes are short so outdoor units have to be installed on wall surfaces.
- 4 Insufficient pipe length makes installation impossible.

### FS Multi System Solution

Piping can be minimized to reduce the load on the building. Pipe installation time can be minimized. Exceptional installation flexibility.

- 1 Minimum number of outdoor units thanks to multi system. Rooftop space can be used effectively.
- 2 Outdoor units can be installed in one location to maintain the building's appearance.
- 3 Pipe shafts can be located together in one place.

### When installation space is limited

A single compact FS Multi system outdoor unit enables air conditioning in multiple rooms, solving the problems of narrow or limited installation space.

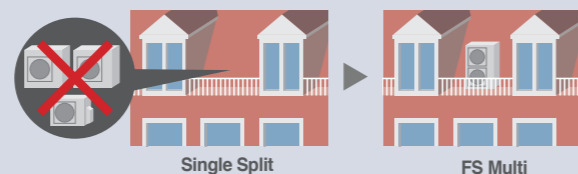

# Technology

## Installation Flexibility

### Refrigerant Charge-free System

The FS Multi is a refrigerant charge-free system that does not require a charge of additional refrigerant even when using a full pipe length of up to 90m. This dramatically shortens the installation time required for charging with additional refrigerant, weight measurement and pressure judgment. It also eliminates charge amount calculation and there's less chance of a cooling capacity shortage due to an incorrect amount of refrigerant being used or other errors.

### Pipes of Up to 90 M

The total length of the pipe between a system's indoor and outdoor units can be extended up to 90 metres, with a height difference of up to 30 metres. These ample limits make it possible to place the outdoor unit on the roof. The maximum height difference between indoor units in the same system may be up to 15 metres, thus covering 4 or 5 floors in the same system.

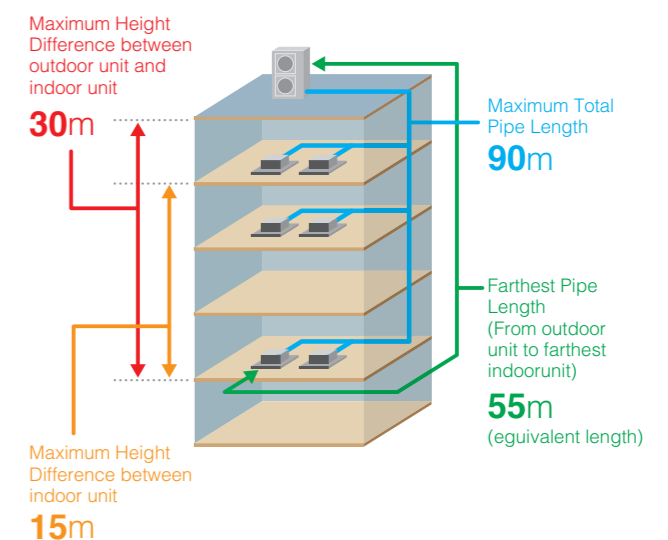

### Space-Saving Design

Improvement of the outdoor unit's fan has reduced the size of the unit to enable installation in a smaller space. Without sacrificing quietness, also higher efficiency is attained. More freedom in installation contributes to the easy piping and facilitates installation. It will lead to the reduction in installation cost.

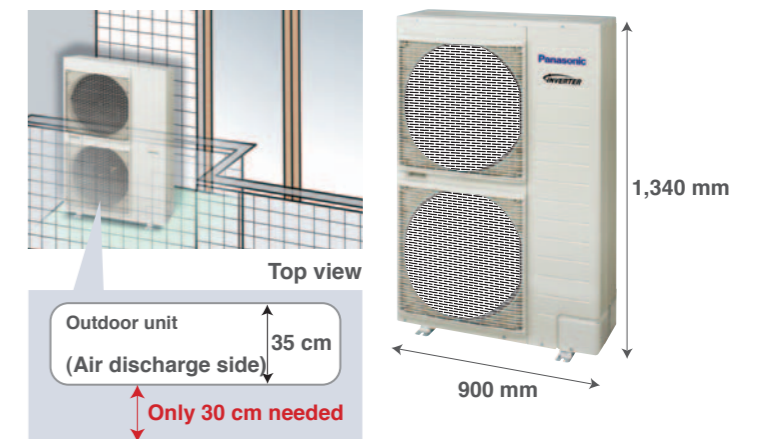

## Energy Saving Inverter

All models of Panasonic's FS Multi series are equipped with DC inverter compressor technology for higher EER operation. The new design attains quiet and efficient operation whilst reducing running costs.

### Hyper Wave Inverter

Panasonic's experience in the development of inverters is realised in the creation of Hyper Wave technology. This control of the inverter demonstrates the optimum compressor torque. The FS Multi series quickly cools or warms the room to the set temperature and maintains a comfortable condition, whilst ensuring energy efficiency and savings.

#### Our conventional inverter

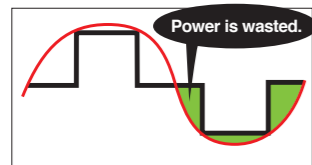

The current waveform deviates from the motor voltage waveform, so power is wasted.

#### Hyper Wave Inverter

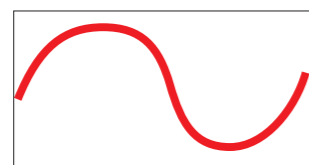

The current waveform closely matches the motor voltage waveform, so power consumption is reduced.

#### Compare this to a car rounding a corner.

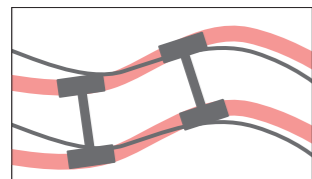

Power is wasted when the car swings off course.

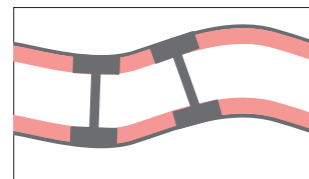

When the car stays right on course, there's no power loss.

**INVERTER**



- 1 Hyper Wave Inverter
- 2 DC Inverter Compressor
- 3 Large Diagonal Air Flow Fan

## Panasonic's Original High-Performance Compressor

It's the compressor at the heart of an air conditioner that determines reliability and efficiency.

The FS Multi features Panasonic's original high-performance compressor to assure outstanding performance and quality.

### High-Efficiency Compressor

Using of a powerful neodymium (rare-metal) magnet for a motor allowed us to make the motor more compact. The winding rotor motor of less magnetic field distortion attains higher efficiency.



## Energy Saving

Quality features translate into energy savings thanks to greater energy efficiency. This efficiency is due to the fact that each room is individually controlled and only the rooms that require air-conditioning are heated or cooled. Moreover, thanks to Inverter technology, the level of air conditioning can be adjusted precisely depending on each room's condition.

### EER / COP value

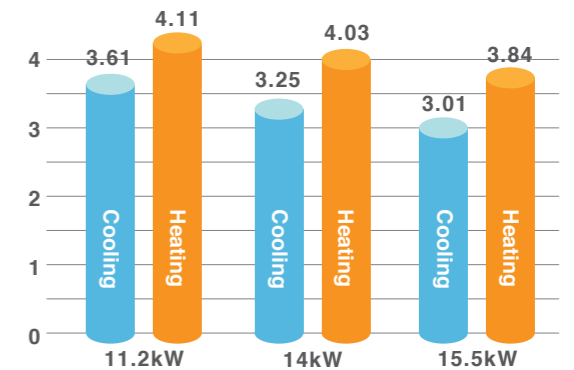

## Broad Operating Range

The heating function will remain stable indoors even when the temperature out-side drops to -15 °C, thus meeting users' different needs. Moreover, the cooling function operates from -5 °C to 43 °C.

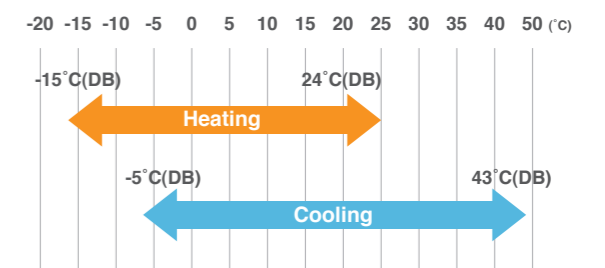

## Quiet Operation

A host of silencing technologies achieves super-quiet operation. We've also improved operating efficiency and reduced energy consumption.

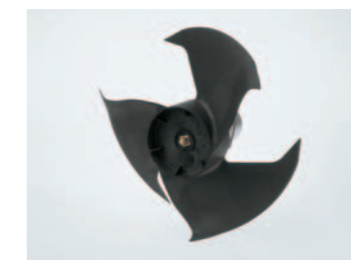

Noise-Suppressing Winglet Fan

## Cooling Only Model Setting

- The unit designed for cooling only can be set by the JP wire on the outdoor unit PC board.
- After setting this mode, the FS Multi system cools only.

## Outdoor Unit Quiet Operation Mode

The Quiet Operation mode of the outdoor unit can be selected by remote control. There are three mode settings that reduce the noise level by up to 6dB(A). (When the Quiet Operation mode is selected, cooling and heating capacity are reduced.)

### Example of 11.2kW model in cooling operation

Reference	Capacity index*	Sound pressure dB(A)
Normal mode	100	52
LV1	80	50
LV2	72	48
LV3	62	46

\* The indexes are nominal capacity operation reference values

# INDIVIDUAL CONTROL SYSTEMS

Unlike conventional air conditioning systems, the VRF system is applied separately to each room. So, this system is ideal for areas with fluctuation in traffic. Moreover, you can have precise control over each of the rooms to achieve exact conditions. Individual control makes this system more cost-effective and efficient.

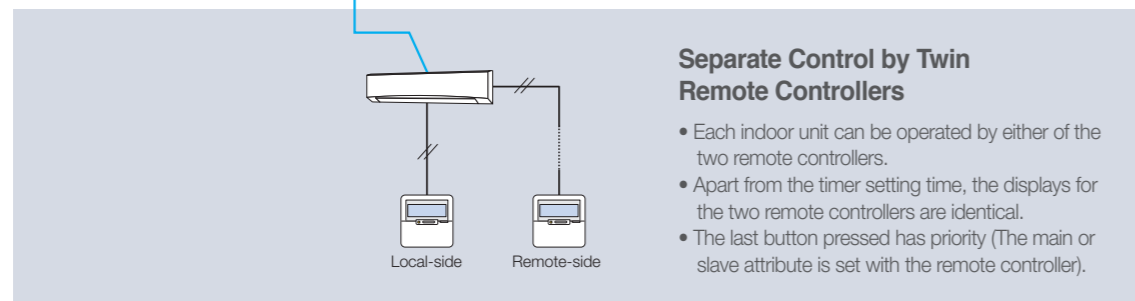
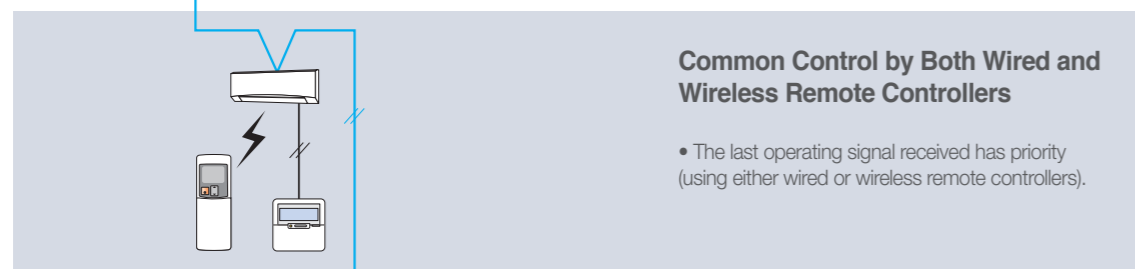
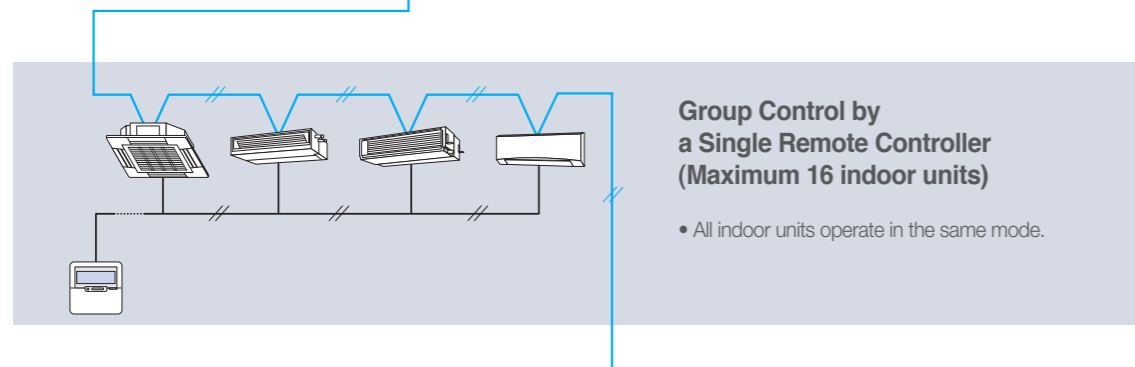
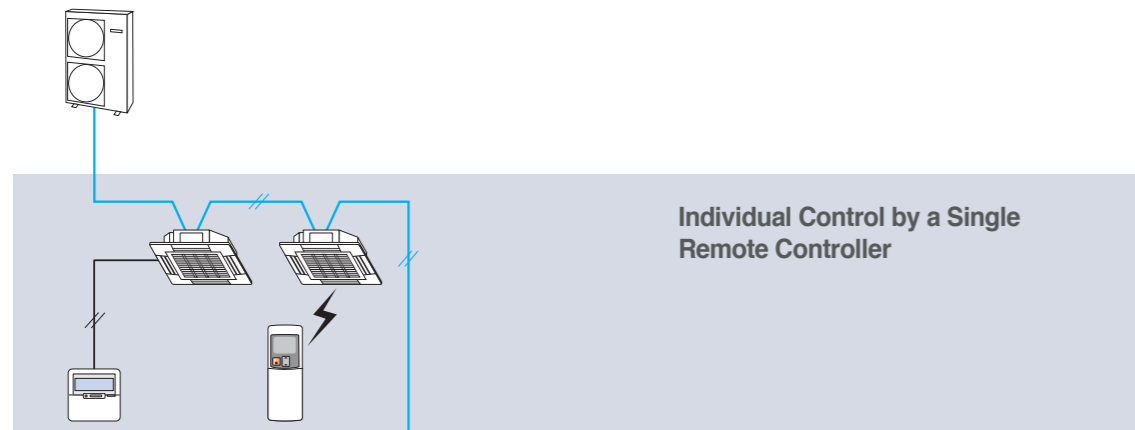

## Wired Remote Controller

### CZ-RT1

- Remote controller with LCD and self-diagnosis
- Constant monitoring of the system with fault detection
- Weekly timer function
- Maintenance time and cost reduction

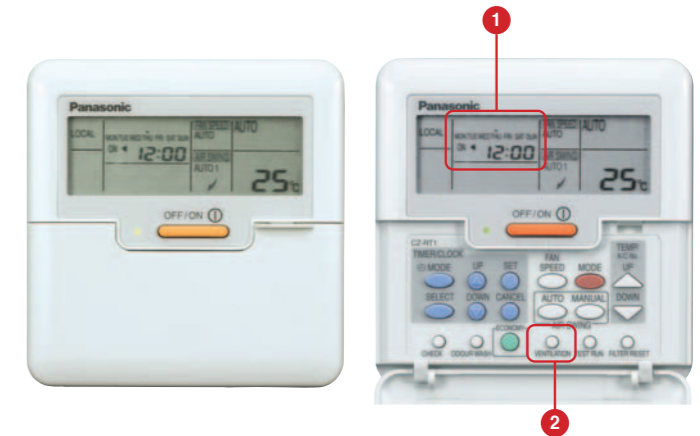

#### OPERATING BUTTONS

- ON/OFF
- Real time daily timer
- Weekly timer : 6 actions per day (total 42) Programme temperature or temperature limits.
- Temperature adjustment
- Adjusting air direction
- Selection of operating mode
- Fan speed control
- Restart filter counter
- Ventilation interlink

#### MONITOR

- Operating mode
- Centralised control indicator
- Operation priority indicator
- Group control indicator
- Selected temperature
- Air direction
- Clock
- Day of the week indicator
- Inspection/operating test
- Fan speed
- Air filter
- Defrost/hot start indicator
- Error mode display

### 1 Weekly Timer

Weekly timer setting (each day of a week) is available to control the air conditioner. Max. 6 settings/day and 42 settings/week can be executed. The setting temperature can be also programmed for optimal comfort.

#### Examples of setting weekly timer

<p><b>Shop with regular holidays</b></p> <p>Example: Closed Saturday afternoon and all day Sunday.</p> <p><b>Mon-Fri On 9:00, Off 18:00</b> <b>Sat On 9:00, Off 12:00</b> <b>Sun Not set</b></p> <p>→ The timer can have different settings for every day of the week.</p>	<p><b>The number of persons varies depending on time zones.</b></p> <p>Example: Set a lower temperature at lunch time when a lot of persons may visit.</p> <p><b>Everyday</b> <b>On 12:00 23°C</b> <b>On 14:00 28°C</b></p> <p>→ In this case, the temperature can be set at the same time.</p>	<p><b>Not to forget to switch OFF</b></p> <p>Example: To prevent forgetting to switch OFF weekdays</p> <p><b>Mon-Fri Off 20:00</b></p> <p>→ The timer can be set for simple shut-off operation.</p>
--	---	---

#### How to set

- Select the day.  
MON TUE WED THU FRI SAT SUN  
ON ◀ 00:00
- Enter the time.  
MON TUE WED THU FRI SAT SUN  
ON ◀ 9:00

**\*Simple Timer Mode**  
Using the 24-hour On/Off timer, the operation of On/Off can be set at a same time everyday.

### 2 Ventilation Interlink

When the external device such as a ventilator is connected to the indoor unit, ON/OFF switching of the ventilator can be controlled by the wired remote control. Either link-ventilation or independent-ventilation is selectable.

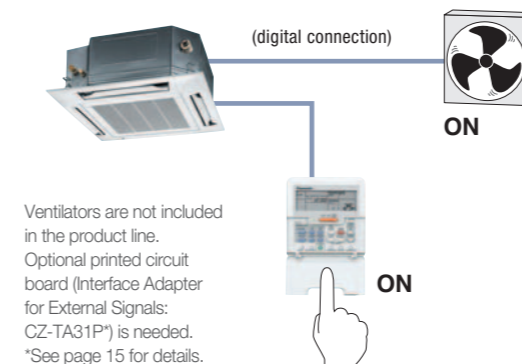

## Shielded Cable for Wired Remote Controller CZ-CCEI

This shielded cable is required when cable longer than 10 m is needed to connect a wired remote controller and an indoor unit \* 1. For easy connection of the remote controller, there is a wired remote controller connector on one end of the cable.

\*1 Conforms to the EMC standard



# CONTROLLERS AND ADAPTERS

## Wireless Remote Controller

### Reverse Cycle Models CZ-RWS1

- Remote controller with LCD and self-diagnosis
- Error code recognition
- Maintenance time and cost reduction
- Real time daily timer

#### OPERATING BUTTONS

- ON/OFF
- Activate/deactivate programmer
- Real time daily timer
- Temperature adjustment
- Air direction
- Operating mode
- Fan speed control
- Restart filter
- Inspection of error code

#### MONITOR

- Operating mode
- Temperature selected
- Air direction
- Time programming
- Error code display
- Fan speed
- Clock



## Wireless Controller Receiver

### for Large Cassette type CZ-RWRU1



for Cassette

### for Ducted type CZ-RWRM1



Wireless receivers for wall-mounted and 60x60 Cassette types are equipped as standard.

## Cooling/Heating Controller for the Outdoor Unit CZ-RD1

Enables remote setting of cooling, heating and ventilating mode for each outdoor unit. Allows the operating mode to be changed for several outdoor units at the same time by means of a single remote control.



## Interface Adapter for External Signals

### CZ-TA31P\*

- By connecting to the indoor unit, a separately sold ventilator can be controlled.
- Remote operation control of the indoor unit is enabled (ON/OFF control).
- The operating condition of the indoor unit (malfunctions, operating status) can be externally output.
- Control in linkage with a Energy Recovery Ventilators (ERV) and the like is possible.

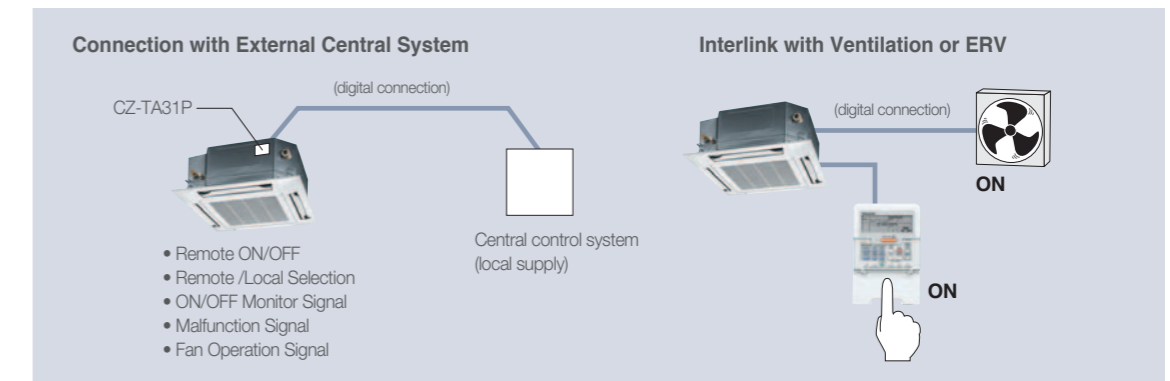
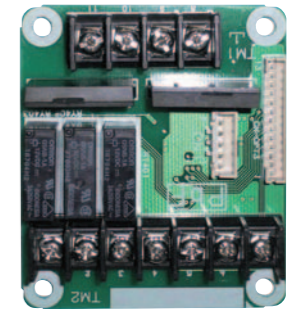

\*CZ-TA31P NOT applicable for wall-mounted indoor unit

## Terminal Module (Equipped as Standard on the Outdoor Unit)

- Control terminal to be connected with outside devices or CZ-RD1 controller.
- Used to receive forced stop digital signal from local procured central control system.
- Used to receive demand control signal from local procured central control system. (Demand control for energy saving with 3-level selection)\*
- Required to connect with CZ-RD1 cooling/heating controller.
- Group control of several FS Multi systems for forced stop and CZ-RD1 cooling/heating controller.

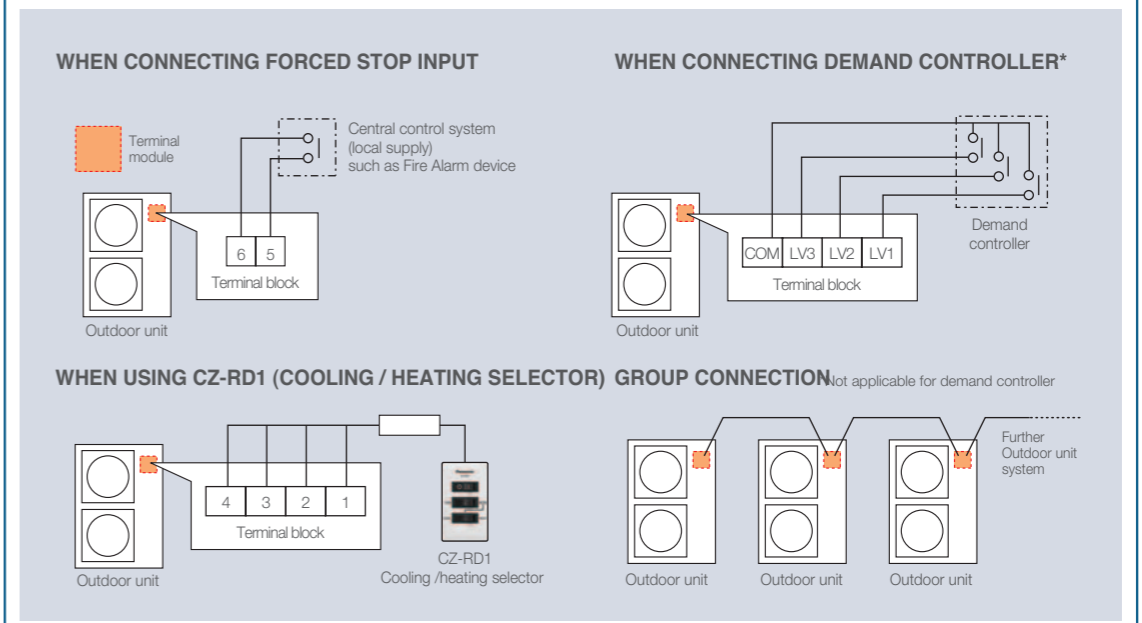
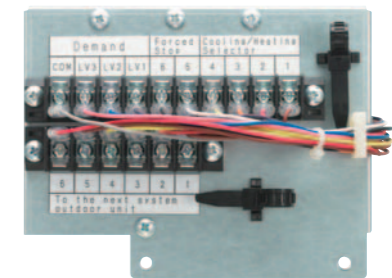

\* Panasonic proprietary feature only, not designed to meet or comply with AS4755.3



# COMBINATION TABLE

The FS Multi system attains maximum indoor unit connection capacity of up to 130% in the unit's connection range, depending on the outdoor and indoor models selected. In the case of a 6HP outdoor unit (15.5kW/53,000Btu/h), connection is possible with a maximum indoor unit range of 20.15kW. So for a reasonable investment, the FS Multi system provides an ideal air conditioning solution for locations where full cooling/heating is not always required.

## COMBINATION TABLE

Reference	Outdoor unit System cooling capacity	Maximum indoor unit	Standard combination capacity*	Maximum combination capacity	Minimum combination capacity
U-4LA1E5	11.2kW/ 38,200 Btu/h	6	11.2kW	14.56kW	5.6kW
U-5LA1E5	14.0kW/ 47,800 Btu/h	8	14.0kW	18.20kW	7.0kW
U-6LA1E5	15.5kW/ 52,900 Btu/h	8	15.5kW	20.15kW	7.75kW
			100%	130%	50%

\*Standard combination capacity is the system's maximum cooling capacity.

## COMBINATION EXAMPLE

Correct					
	Reference	Quantity	Capacity	Minimum combination capacity	Maximum combination capacity
Outdoor	U-6LA1E5	1	15.5 kW*	7.75 kW	20.15 kW
Indoor	S-22KA1E5	1	2.2 kW	-	-
	S-36KA1E5	2	(3.6×2)7.2 kW	-	-
	S-22NA1E5	1	2.2 kW	-	-
	S-28NA1E5	3	(2.8×3)8.4 kW	-	-
	<b>Total indoor capacity</b>		<b>7</b>	<b>20.0 kW(129%)</b>	

Incorrect					
	Reference	Quantity	Capacity	Minimum combination capacity	Maximum combination capacity
Outdoor	U-6LA1E5	1	15.5 kW*	7.75 kW	20.15 kW
Indoor	S-22KA1E5	1	2.2 kW	-	-
	S-36KA1E5	2	(3.6×2)7.2 kW	-	-
	S-45KA1E5	1	4.5 kW	-	-
	S-22NA1E5	1	2.2 kW	-	-
	S-28NA1E5	3	(2.8×3)8.4 kW	-	-
	<b>Total indoor capacity</b>		<b>8</b>	<b>24.5 kW(158%)</b>	

\*Standard combination capacity is the system's maximum cooling capacity.

## Branch Pipe

### R410A BRANCHES

The use of branch piping combined with expansion valves mounted in VRF indoor unit considerably reduces the imbalance of the refrigerant liquid flow between indoor units despite the smaller piping diameter. The joints for these pipes have been designed to reduce installation time, as they are easy to fit. Finally, the branch pipes optimise refrigerant flow.

\*Only genuine Panasonic branch pipes must be used.

### CZ-P155BK1

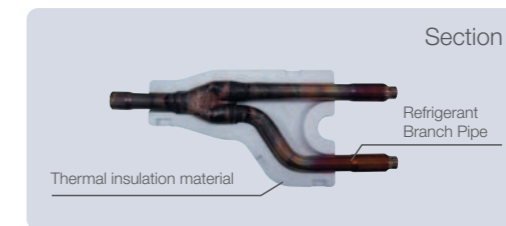

Applicable to all types of FS Multi indoor and outdoor units.

### Details of parts supplied

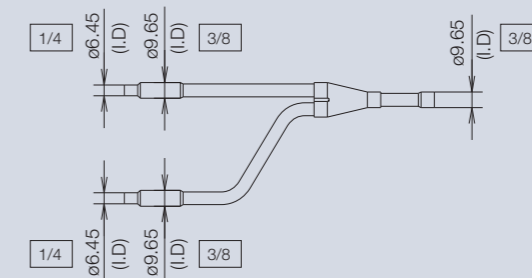

#### 1 Liquid side branch pipe (inner diameter)

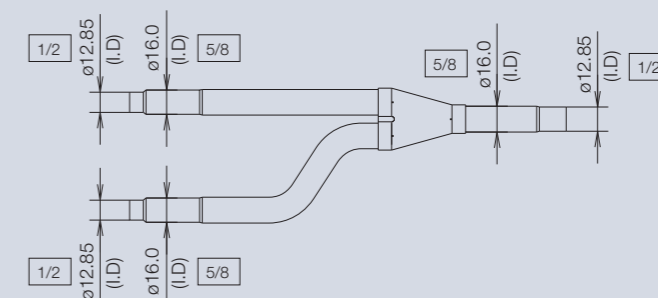

#### 2 Gas side branch pipe (inner diameter)



# OUTDOOR UNIT

Power (kW)	11.2kW	14kW	15.5kW
Reference	 <b>U-4LA1E5</b>	 <b>U-5LA1E5</b>	 <b>U-6LA1E5</b>
Maximum combination of indoor unit	6	8	8
Power rates (kW)	5.6 - 11.2 - 14.56	7.0 - 14.0 - 18.20	7.75 - 15.5 - 20.15
Power supply (V/Hz)	230/50	230/50	230/50

## Control Flexibility

- Cooling Only Model Setting (by jumper line cut)
- Power Save Mode
- Outdoor Unit Silent Operation Mode
- Auto Restart

## Field Service & Maintenance

- Pump Down Operation
- Cooling Operation TESTRUN
- Heating Operation TESTRUN
- Automatic Address Resetting
- Self Diagnosis Function (LED display)

## Digital Input/Output

- Cooling/Heating Selector
- Demand Control Input (LV1/LV2/LV3)\*
- Forced STOP Input

\* Panasonic proprietary feature only, not designed to meet or comply with AS4755.3

## Dimensions

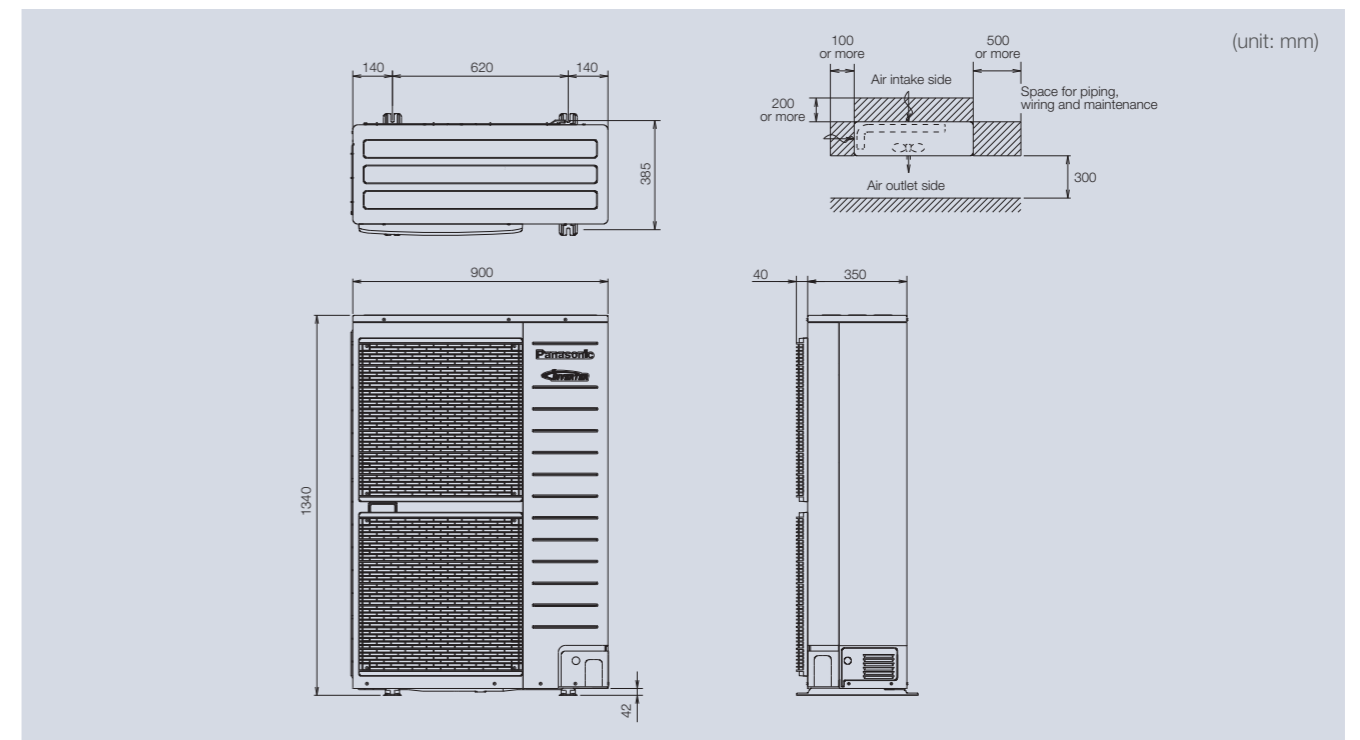

## Specification



Power (kW)		11.2kW	14kW	15.5kW	
<b>Model number</b>		<b>U-4LA1E5</b>	<b>U-5LA1E5</b>	<b>U-6LA1E5</b>	
Power Source	phase	1ø	1ø	1ø	
	V	240	240	240	
	Hz	50Hz	50Hz	50Hz	
Cooling	Capacity	kW [Btu/h]	11.20 [38,200]	14.00 [47,800]	15.50 [52,900]
	Power Input	W	3,100	4,310	5,150
	EER	W/W [Btu/h]	3.61 [12.32]	3.25 [11.09]	3.01 [10.27]
	Current	A	13.60	19.00	22.50
	Air Volume	Litre/s	1,533	1,583	1,633
	Sound Pressure Level	Hi/Lo dB [A]	52/-	53/-	55/-
	Sound Power Level	Hi/Lo dB	70/-	71/-	73/-
Operating Range	Min. - Max. °C	-5°C - 43°C	-5°C - 43°C	-5°C - 43°C	
Heating	Capacity	kW [ Btu/h]	12.50 [42,700]	16.00 [54,600]	18.00 [61,400]
	Power Input	W	3,040	3,970	4,690
	COP	W/W [Btu/h]	4.11 [14.04]	4.03 [13.75]	3.84 [13.09]
	Current	A	13.40	17.40	20.50
	Air Volume	Litre/s	1,533	1,583	1,633
	Sound Pressure Level	Hi/Lo dB [A]	54/-	55/-	57/-
	Sound Power Level	Hi/Lo dB	71/-	72/-	74/-
Operating Range	Min. - Max. °C	-15°C - 24°C	-15°C - 24°C	-15°C - 24°C	
Connectable Indoor Unit	Total Capacity	50~130% of Outdoor Unit Capacity			
	Model/City	unit	S-22 - S-90 /2 - 6	S-22 - S-90 /2 - 8	S-22 - S-90 /2 - 8
Moisture Removal Volume	L/h [Pt/h]		6.8 [14.3]	9.0 [18.9]	10.3 [21.6]
Dimensions	HxWxD	mm	1,340x900x350(+40)* <sup>1</sup>		
		[inch]	52-3/4x35-7/16x13-25/32(+1-9/16)		
Net Weight	kg [lb]		115 [253]	123 [271]	123 [271]
Piping Connection	Liquid Side	mm [inch]	ø9.52 [3/8]		
	Gas Side	mm [inch]	15.88 [5/8]		
Maximum Total Piping Length	Min. - Max. m [ft]		20 - 90 [65.6 - 295.2]	20 - 90 [65.6 - 295.2]	20 - 90 [65.6 - 295.2]
Height Difference (Maximum)	Max m [ft]		30 [98.4]	30 [98.4]	30 [98.4]
Max Chargeless Length	Max m [ft]		90 [295.2]	90 [295.2]	90 [295.2]
Refrigerant			R410A / 7kg	R410A / 8kg	R410A / 8kg



\*1 Add 40mm for discharge grille.

Rating Conditions	Cooling	Heating
Inside air temperature	27°C DB/19°C WB	20°C DB
Outside air temperature	35°C DB/24°C WB	7°C DB/6°C WB

# FS MULTI PRODUCT LINEUP

## Indoor Unit

Capacity	Cooling Heating	refrigerant	2.2kW 2.5kW	2.8kW 3.2kW	3.2kW 3.6kW	3.6kW 4.2kW	4.5kW 5.1kW	5.6kW 6.4kW	6.3kW 7.1kW	7.1kW 8.0kW	9.0kW 10.0kW
Wall-Mounted Type		R410A	 S-22KA1E5	 S-28KA1E5		 S-36KA1E5	 S-45KA1E5	 S-56KA1E5	 S-63KA1E5	 S-71KA1E5	
Cassette Type		R410A							 S-63UA1E5	 S-71UA1E5	 S-90UA1E5
60x 60 Cassette Type		R410A	 S-22YA1E5	 S-28YA1E5		 S-36YA1E5	 S-45YA1E5	 S-56YA1E5			
Low-Silhouette Duct Type (Low static pressure type)		R410A	 S-22NA1E5	 S-28NA1E5	 S-32NA1E5	 S-36NA1E5	 S-45NA1E5	 S-56NA1E5			
Low-Silhouette Duct Type (Mid static pressure type)		R410A					 S-45MA1E5	 S-56MA1E5	 S-63MA1E5	 S-71MA1E5	 S-90MA1E5

Power (kW)			11.2kW	14kW	15.5kW
Capacity	Cooling Heating	refrigerant	11.2kW 12.5kW	14.0kW 16.0kW	15.5kW 18.0kW
Outdoor Unit		R410A	 U-4LA1E5	 U-5LA1E5	 U-6LA1E5



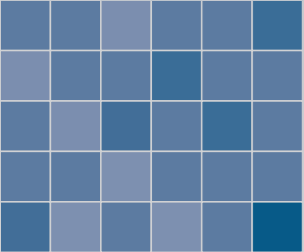

# Wall-Mounted Type

Eco Inspired Design.  
Cool, Stylish and Energy-Saving



**S-22KA1E5**



**S-56KA1E5** Wide model

FS Multi wall-mounted type air conditioners have been designed in a beautiful and stylish way. The fresh new horizontal curved form characterizes the air conditioner's new design. The gentle curve at the center stylishly conceals the complex high-performance mechanisms inside, while thin ends emphasize the air conditioner's slim style. This allows it to blend into the wall in an attractive manner, and to add harmony to virtually any room interior.



# Wall-Mounted Type



Wide model

## Flexible Installation

Panasonic wall mounted model, compact and stylish design, is installable in a very limited space, without the feeling of pressure, it can integrate into your stylish room interiors.

## Effective Long-life Filter

This long-life filter can trap dust mites, tobacco smoke, and other common pollutants effectively. You can remove the filter quickly with a simple one step operation, after cleaning, it can be replaced back.

## Self Diagnosis Function with 7-Seg Code Display

When air conditioner has trouble, the indicator and 7-seg code displays on the panel making it easier for service technicians to diagnose problems.

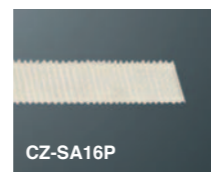

## Optional Accessories

SUPER alleru-buster filter - 10-year filter life

**CZ-SA16P**

Replacement: every 10 years

## Features

### Control Flexibility

- 24-Hours ON/OFF Real Setting Timer
- Weekly Timer (Wired Only)
- Group Control by Single Remote Controller
- Outdoor Unit Silent Operation Mode
- Indoor Unit Thermistor Switching (Wired Only)
- Timer Output

### Comfort

- Filter Sign
- Hot Start Control
- Filter
- Super alleru-buster filter (optional/10-year lifetime)

### Field Service & Maintenance

- Indoor Unit Address Setting
- Outdoor Unit Address Setting
- Automatic Address Resetting for Group Control (Wired Only)
- Indoor Unit Test Run Mode
- Emergency Operation (Infrared Only)
- Self Diagnosis Function
- Self Diagnosis Records (Wired Only)

\*Wired: Wired Remote Controller / Infrared: Infrared Remote Controller  
For more detail, see the feature comparisons of P34-35

## Dimensions

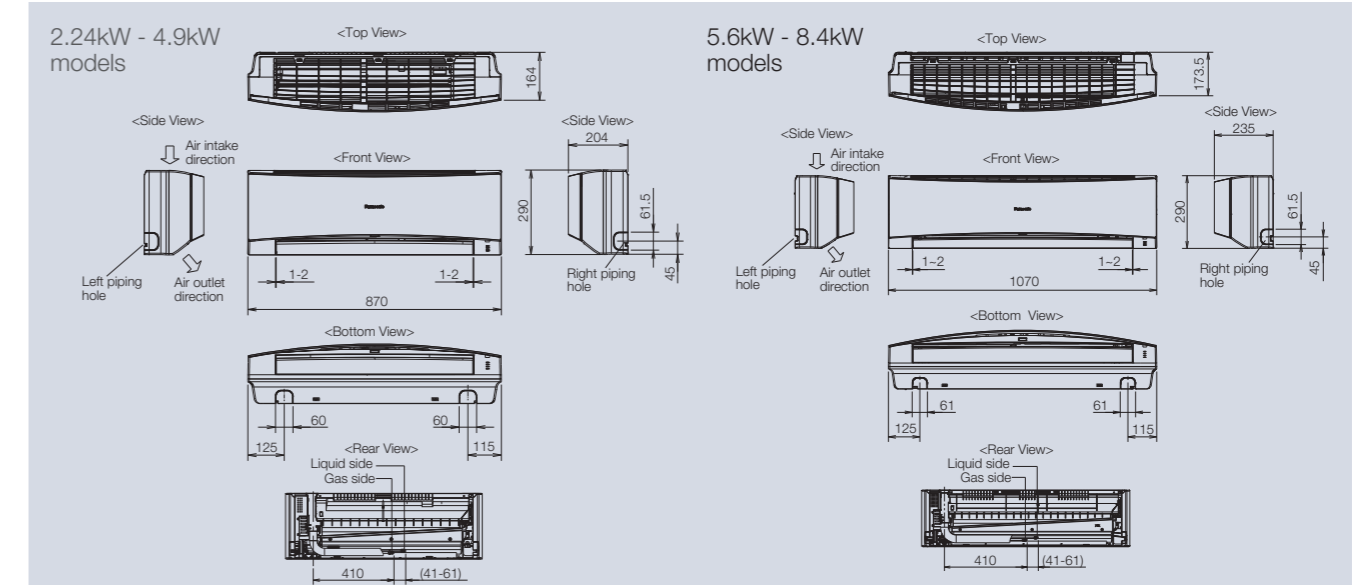

## Specification

Power (kW)		2.2kW	2.8kW	3.6kW	4.5kW	
Indoor		S-22KA1E5	S-28KA1E5	S-36KA1E5	S-45KA1E5	
Power Source	phase	1ø	1ø	1ø	1ø	
	V	240	240	240	240	
	Hz	50Hz	50Hz	50Hz	50Hz	
Cooling	Capacity	kW [Btu/h]	2.20 [7,500]	2.80 [9,600]	3.60 [12,300]	4.50 [15,400]
	Power Input	W	25	27	30	35
	Current	A	0.25	0.30	0.35	0.40
	Air Volume	Hi Litre/s	158	162	182	188
	Sound Pressure Level	Hi/Lo dB [A]	38/33	39/33	42/34	43/35
Heating	Capacity	kW [Btu/h]	2.50 [8,500]	3.20 [10,900]	4.20 [14,300]	5.10 [17,400]
	Power Input	W	25	27	30	35
	Current	A	0.25	0.30	0.35	0.40
	Air Volume	Hi Litre/s	172	182	193	202
	Sound Pressure Level	Hi/Lo dB [A]	38/33	39/33	42/34	43/35
Moisture Removal Volume	L/h [Pt/h]	1.3 [2.7]	1.6 [3.4]	2.1 [4.4]	2.5 [5.3]	
Dimensions (H×W×D)	mm	290×870×204	290×870×204	290×870×204	290×870×204	
	inch	11-7/16×34-9/32 ×8-1/16	11-7/16×34-9/32 ×8-1/16	11-7/16×34-9/32 ×8-1/16	11-7/16×34-9/32 ×8-1/16	
Net Weight	kg [lb]	9 [20]	9 [20]	9 [20]	9 [20]	
Piping Connection	Liquid Side	mm [inch]	ø6.35 [1/4]	ø6.35 [1/4]	ø6.35 [1/4]	
	Gas Side	mm [inch]	ø12.7 [1/2]	ø12.7 [1/2]	ø12.7 [1/2]	

Power (kW)		5.6kW	6.3kW	7.1kW	
Indoor		S-56KA1E5	S-63KA1E5	S-71KA1E5	
Power Source	phase	1ø	1ø	1ø	
	V	240	240	240	
	Hz	50Hz	50Hz	50Hz	
Cooling	Capacity	kW [Btu/h]	5.60 [19,100]	6.30 [21,500]	7.10 [24,200]
	Power Input	W	45	50	55
	Current	A	0.40	0.45	0.50
	Air Volume	Hi Litre/s	255	267	290
	Sound Pressure Level	Hi/Lo dB [A]	44/38	46/39	48/40
Heating	Capacity	kW [Btu/h]	6.40 [21,800]	7.10 [24,200]	8.00 [27,300]
	Power Input	W	45	50	55
	Current	A	0.40	0.45	0.50
	Air Volume	Hi Litre/s	278	285	305
	Sound Pressure Level	Hi/Lo dB [A]	44/38	46/39	48/40
Moisture Removal Volume	L/h [Pt/h]	3.2 [6.7]	3.6 [7.6]	4.2 [8.8]	
Dimensions (H×W×D)	mm	290×1,070×235	290×1,070×235	290×1,070×235	
	inch	11-7/16×42-5/32 ×9-9/32	11-7/16×42-5/32 ×9-9/32	11-7/16×42-5/32 ×9-9/32	
Net Weight	kg [lb]	11 [24]	12 [26]	12 [26]	
Piping Connection	Liquid Side	mm [inch]	ø6.35 [1/4]	ø6.35 [1/4]	ø9.52 [3/8]
	Gas Side	mm [inch]	ø12.7 [1/2]	ø12.7 [1/2]	ø15.88 [5/8]

Rating Conditions	Cooling	Heating
Inside air temperature	27°C DB/19°C WB	20°C DB
Outside air temperature	35°C DB/24°C WB	7°C DB/6°C WB

Before installing in quiet room such as a bedroom, please consult with an authorized distributor.

# Cassette (60x60) Type



70mm Square Panel CZ-KPY1 (Optional)



## 4-Way Airflow Comfort with Elegant, Compact Panel

### Compact Design Allows Space Saving!

The panel is a compact 70x70cm so it can be installed even in a small room where space is limited. The ceiling opening is required 65x65cm.

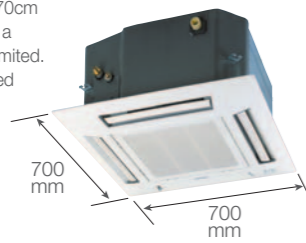

### Self Diagnosis Function with 7-Seg Code Display

When the air conditioner has trouble, the indicator and 7-seg code displays on the panel making it easier for service technicians to diagnose problems.



### Only 260mm Thin and 750 mm Drain-Up Mechanism

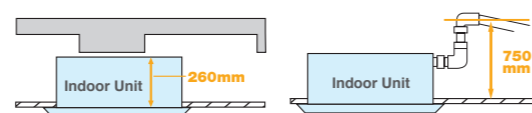

With only 260mm high body, fits easily in ceiling spaces and tight spots.

The internal pump allows the drain line to be elevated up to 750 mm above the base of the unit.

### Anti-Mould Long-Life Air Filter

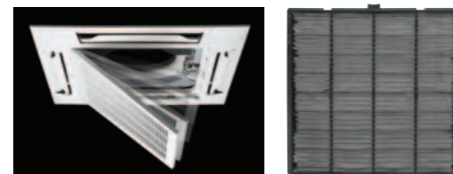

\* For optimum comfort, we recommend cleaning the air filter every 1.5 months.

### Optional Accessories



**SUPER**  
alleru-buster filter  
**CZ-SA13P**  
Replacement: every 3 years

## Features

### Control Flexibility

- 24-Hours ON/OFF Real Setting Timer
- Weekly Timer (Wired Only)
- Group Control by Single Remote Controller
- Outdoor Unit Silent Operation Mode
- Indoor Unit Thermistor Switching (Wired Only)
- Ventilation Unit Control (Wired Only)
- Timer Output
- Digital Input/Output Contact - with CZ-TA31P (Optional)

### Comfort

- Filter Sign
- Hot Start Control
- Filter
- Super alleru-buster filter (optional/3-year lifetime)
- Fresh air inlet

### Field Service & Maintenance

- Indoor Unit Address Setting
- Outdoor Unit Address Setting
- Automatic Address Resetting for Group Control (Wired Only)
- Indoor Unit Test Run Mode
- Emergency Operation (Infrared Only)
- Self Diagnosis Function
- Self Diagnosis Records (Wired Only)

\*Wired: Wired Remote Controller / Infrared: Infrared Remote Controller  
For more detail, see the feature comparisons of P34-35

## Dimensions

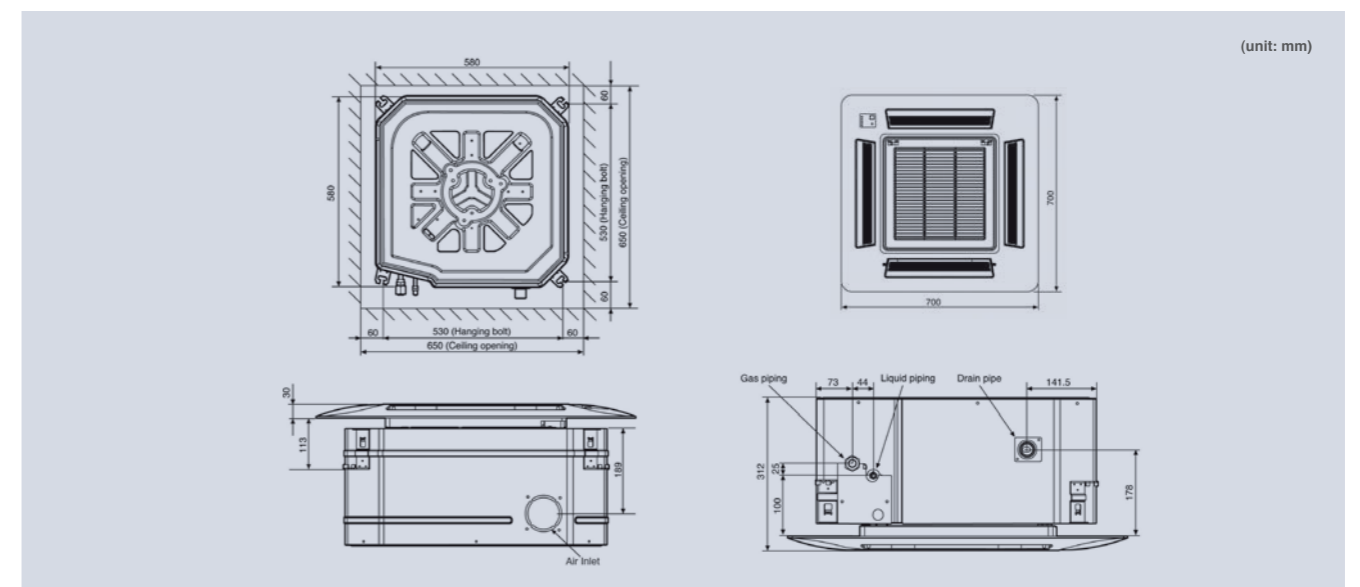

## Specification

Power (kW)		2.2kW	2.8kW	3.6kW	4.5kW	5.6kW		
Indoor		S-22YA1E5	S-28YA1E5	S-36YA1E5	S-45YA1E5	S-56YA1E5		
Panel		CZ-KPY1	CZ-KPY1	CZ-KPY1	CZ-KPY1	CZ-KPY1		
Power Source	phase	1ø	1ø	1ø	1ø	1ø		
	V	240	240	240	240	240		
	Hz	50Hz	50Hz	50Hz	50Hz	50Hz		
Cooling	Capacity	kW [Btu/h]	2.20 [7,500]	2.80 [9,600]	3.60 [12,300]	4.50 [15,400]	5.60 [19,100]	
	Power Input	W	35	35	40	40	45	
	Current	A	0.30	0.30	0.35	0.35	0.35	
	Air Volume	Hi	Litre/s	138	143	150	155	165
	Sound Pressure Level	Hi/Lo	dB [A]	36/33	37/33	38/34	39/35	40/36
Heating	Capacity	kW [Btu/h]	2.50 [8,500]	3.20 [10,900]	4.20 [14,300]	5.10 [17,400]	6.40 [21,800]	
	Power Input	W	35	35	40	40	45	
	Current	A	0.30	0.30	0.35	0.35	0.35	
	Air Volume	Hi	Litre/s	155	160	165	172	177
	Sound Pressure Level	Hi/Lo	dB [A]	36/33	37/33	38/34	39/35	40/36
Moisture Removal Volume	L/h [Pt/h]	1.3 [2.7]	1.6 [3.4]	2.1 [4.4]	2.5 [5.3]	3.2 [6.7]		
Dimensions (HxWxD)	Indoor unit	mm	260x575x575	260x575x575	260x575x575	260x575x575	260x575x575	
	Panel	mm	51x700x700	51x700x700	51x700x700	51x700x700	51x700x700	
Net Weight		kg [lb]	18 [40]	18 [40]	18 [40]	18 [40]	18 [40]	
	Piping Connection	Liquid Side	mm [inch]	ø6.35 [1/4]	ø6.35 [1/4]	ø6.35 [1/4]	ø6.35 [1/4]	ø6.35 [1/4]
	Gas Side	mm [inch]	ø12.7 [1/2]	ø12.7 [1/2]	ø12.7 [1/2]	ø12.7 [1/2]	ø12.7 [1/2]	

Rating Conditions	Cooling	Heating
Inside air temperature	27°C DB/19°C WB	20°C DB
Outside air temperature	35°C DB/24°C WB	7°C DB/6°C WB

# Cassette Type

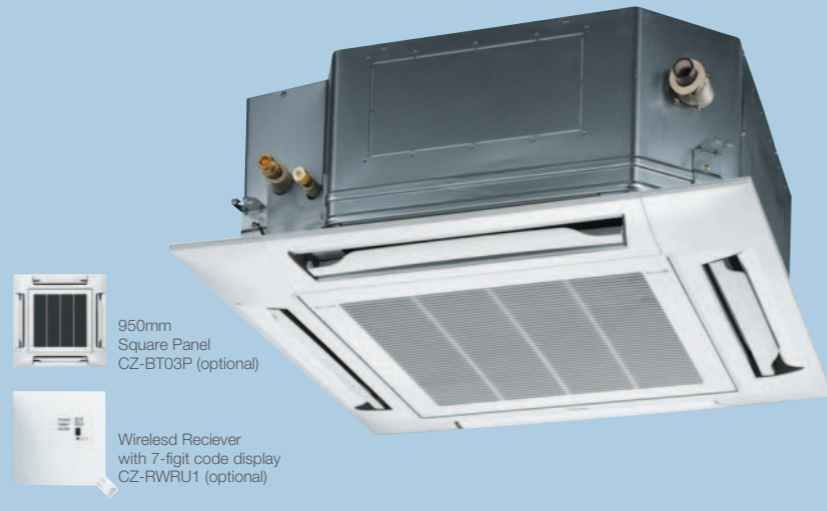

950mm Square Panel CZ-BT03P (optional)  
Wireless Receiver with 7-digit code display CZ-RWRU1 (optional)

## 4-Way Airflow Comfort with Elegant, Compact Panel

### Only 240mm Thin and 750 mm Drain-Up Mechanism

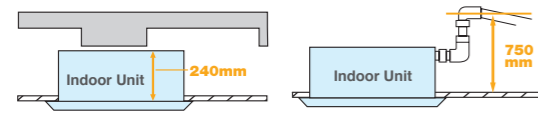

With only 240mm high body, fitting easily in ceiling spaces and tight spots.

The internal pump allows the drain line to be elevated up to 750 mm above the base of the unit.

### Elegant Panel, 4-direction Blow

The thin and delicate body can be totally hidden in the ceiling, only leaving its elegant panel outside to decorate your room. The 4-direction blow can deliver airflows evenly throughout the room, eliminating the temperature difference.



### Three Airflow Patterns for Extra Comfort

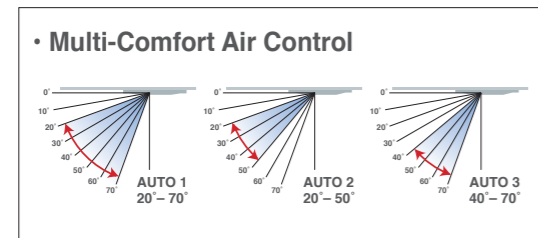

### Self Diagnosis Function with 7-Seg Code Display

When air conditioner has trouble, the indicator and 7-seg code displays on the panel making it easier for service technicians to diagnose problems.



### Flexible Piping Layout

Drainpipe and refrigerant pipe distributed on the different sides of the unit, giving more flexibility of piping layout. Its excellent inside heat-protection material effectively avoids frost and water-leakage, and reduces the damage possibility in the transportation.



### Anti-Mould Long-Life Air Filter

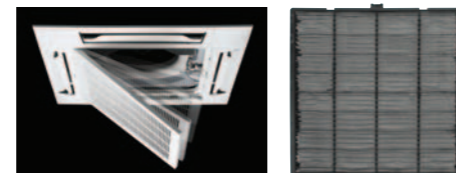

\* For optimum comfort, we recommend cleaning the air filter every 1.5 months.

### Innovative Design Creates Extra Quiet Operation

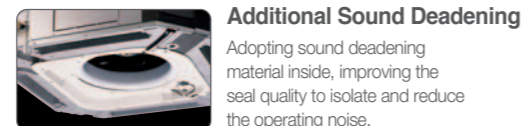

**Additional Sound Deadening**  
Adopting sound deadening material inside, improving the seal quality to isolate and reduce the operating noise.

## Features

### Control Flexibility

- 24-Hours ON/OFF Real Setting Timer
- Weekly Timer (Wired Only)
- Group Control by Single Remote Controller
- Outdoor Unit Silent Operation Mode
- Indoor Unit Thermistor Switching (Wired Only)
- Ventilation Unit Control (Wired Only)
- Timer Output
- Digital Input/Output Contact - with CZ-TA31P (Optional)

### Comfort

- Filter Sign
- Hot Start Control
- Filter
- Satellite Duct
- Fresh Air Inlet

### Field Service & Maintenance

- Indoor Unit Address Setting
- Outdoor Unit Address Setting
- Automatic Address Resetting for Group Control (Wired Only)
- Indoor Unit Test Run Mode
- Emergency Operation (Infrared Only)
- Self Diagnosis Function
- Self Diagnosis Records (Wired Only)

\*Wired: Wired Remote Controller / Infrared: Infrared Remote Controller  
For more detail, see the feature comparisons of P34-35

## Dimensions

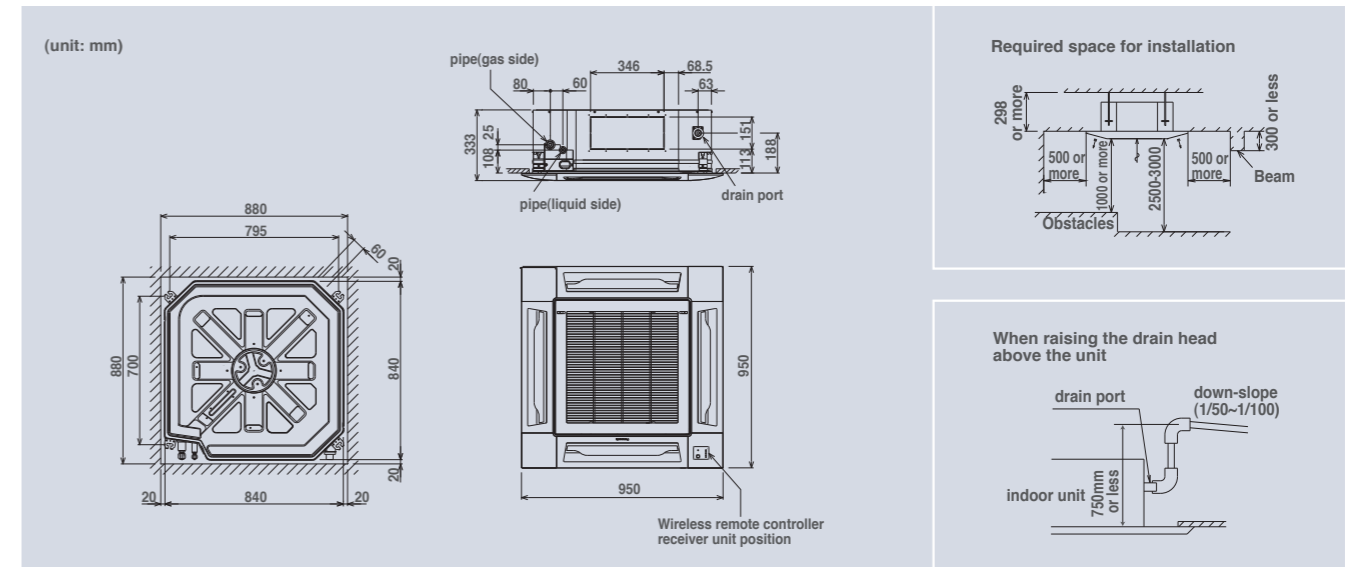

## Specification

Power (kW)		6.3kW	7.1kW	9.0kW		
Indoor		S-63UA1E5	S-71UA1E5	S-90UA1E5		
Panel		CZ-BT03P	CZ-BT03P	CZ-BT03P		
Power Source		phase	1ø	1ø		
		V	240	240		
		Hz	50Hz	50Hz		
Cooling	Capacity	kW [Btu/h]	6.30 [21,500]	7.10 [24,200]	9.00 [30,700]	
	Power Input	W	115	120	120	
	Current	A	0.55	0.60	0.60	
	Air Volume	Hi	Litre/s	350	367	367
	Sound Pressure Level	Hi/Lo	dB [A]	41/36	42/37	42/37
	Sound Power Level	Hi/Lo	dB	56/51	57/52	57/52
Heating	Capacity	kW [Btu/h]	7.10 [24,200]	8.00 [27,300]	10.00 [34,100]	
	Power Input	W	115	120	120	
	Current	A	0.55	0.60	0.60	
	Air Volume	Hi	Litre/s	350	367	367
	Sound Pressure Level	Hi/Lo	dB [A]	41/36	42/37	42/37
	Sound Power Level	Hi/Lo	dB	56/51	57/52	57/52
Moisture Removal Volume		L/h [Pt/h]	3.6 [7.6]	4.2 [8.8]	5.4 [11.3]	
Dimensions		Indoor unit	mm	246x840x840	246x840x840	246x840x840
(HxWxD)		Panel	inch	9-11/16x33-1/16x33/1/16	9-11/16x33-1/16x33/1/16	9-11/16x33-1/16x33/1/16
Net Weight		Panel	mm	45x950x950	45x950x950	45x950x950
			kg [lb]	26 [57]	26 [57]	26 [57]
Piping Connection		Liquid Side	mm [inch]	ø6.35 [1/4]	ø9.52 [3/8]	ø9.52 [3/8]
		Gas Side	mm [inch]	ø12.7 [1/2]	ø15.88 [5/8]	ø15.88 [5/8]

Rating Conditions	Cooling	Heating
Inside air temperature	27°C DB/19°C WB	20°C DB
Outside air temperature	35°C DB/24°C WB	7°C DB/6°C WB

# Low-Silhouette Duct Type

(Low Static Pressure Type)



## Ultra-thin, Duct-type Indoor Unit

The slim design of this ultra-thin, duct-type indoor unit is especially suited for rooms with partially or minimally dropped ceilings. Its space-saving design contributes to a brighter and more spacious living environment.

## Ultra-thin 20 cm Design: Fits in Even Where Ceiling Height is Limited.

Even where ceiling height is limited, the indoor units effectively fit in and provide a more spacious feel in most dropped ceiling situations. Occupying only 20 cm of vertical space and projecting only 55 cm, the unit can be installed in semi-dropped ceiling situations, thus helping to create spacious and comfortable surroundings.



Dropped Ceiling Effect

## Built-in Selectable Static Pressure Settings

Our ultra thin duct-type indoor units have two static pressure settings: 0 Pa and 29 Pa. In situations without ducting, the 0 Pa\* static pressure setting is applicable. Where ducting is present, set the unit to 29 Pa\* static pressure. \*0 Pa is the default setting; 29 Pa must be selected if required.

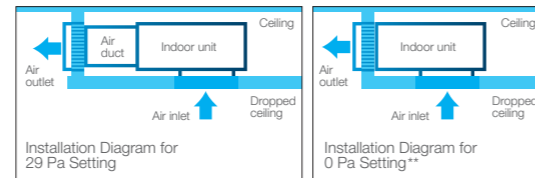

## Thoroughly Considered Connecting Flange Design.

The addition of air duct connecting flanges on the indoor unit enables easy connection to short air ducts. Thus flange design both greatly simplifies installation and makes it easy to effectively seal the air duct.

## Dimensions

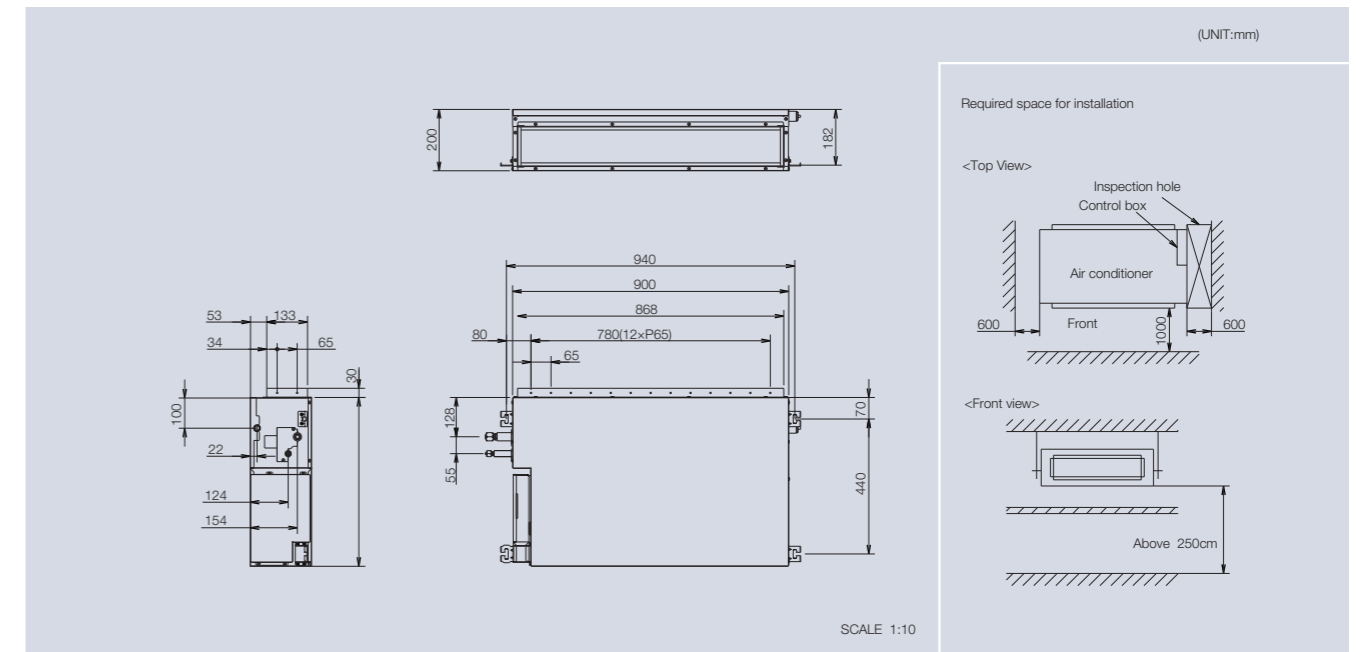

## Specification

		2.2kW	2.8kW	3.2kW	3.6kW	4.5kW	5.6kW	
		S-22NA1E5	S-28NA1E5	S-32NA1E5	S-36NA1E5	S-45NA1E5	S-56NA1E5	
Power (kW)								
Indoor								
Power Source	phase	1ø	1ø	1ø	1ø	1ø	1ø	
	V	240	240	240	240	240	240	
	Hz	50Hz	50Hz	50Hz	50Hz	50Hz	50Hz	
Cooling	Capacity	kW [Btu/h]	2.20 [7,500]	2.80 [9,600]	3.20 [10,900]	3.60 [12,300]	4.50 [15,400]	5.60 [19,100]
	Power Input	W	80	85	90	90	100	110
	Current	A	0.45	0.50	0.50	0.50	0.55	0.55
	Air Volume	Hi Litre/s	167	183	183	183	200	208
	Sound Pressure Level **	Hi/Lo dB [A]	36/31	37/31	38/32	38/32	39/33	39/33
Heating	Capacity	kW [Btu/h]	2.50 [8,500]	3.20 [10,900]	3.60 [12,300]	4.20 [14,300]	5.10 [17,400]	6.40 [21,800]
	Power Input	W	80	85	90	90	100	110
	Current	A	0.45	0.50	0.50	0.50	0.55	0.55
	Air Volume	Hi Litre/s	167	183	183	183	200	208
	Sound Pressure Level **	Hi/Lo dB [A]	36/31	37/31	38/32	38/32	39/33	39/33
Moisture Removal Volume	L/h [Pt/h]	1.3 [2.7]	1.6 [3.4]	1.8 [3.8]	2.1 [4.4]	2.5 [5.3]	3.2 [6.7]	
External Static Pressure *1	Pa [mmAq]	0/29 [0/3]	0/29 [0/3]	0/29 [0/3]	0/29 [0/3]	0/29 [0/3]	0/29 [0/3]	
Dimensions	H×W×D	mm	200×900×550	200×900×550	200×900×550	200×900×550	200×900×550	
		inch	7-7/8×35-7/16 ×21-21/32	7-7/8×35-7/16 ×21-21/32	7-7/8×35-7/16 ×21-21/32	7-7/8×35-7/16 ×21-21/32	7-7/8×35-7/16 ×21-21/32	7-7/8×35-7/16 ×21-21/32
Net Weight		kg[lb]	21 [46]	21 [46]	22 [48]	22 [48]	22 [48]	
Piping Connection		Liquid Side	mm [inch]	ø6.35 [1/4]	ø6.35 [1/4]	ø6.35 [1/4]	ø6.35 [1/4]	ø6.35 [1/4]
		Gas Side	mm [inch]	12.7 [1/2]	12.7 [1/2]	12.7 [1/2]	12.7 [1/2]	12.7 [1/2]

\*1 The external static pressure is set to 0pa at factory default setting.

\*\*Noise levels are for rear return air only, bottom return air setting may increase noise slightly.

## Features

### Control Flexibility

- 24-Hours ON/OFF Real Setting Timer
- Weekly Timer (Wired Only)
- Group Control by Single Remote Controller
- Outdoor Unit Silent Operation Mode
- Indoor Unit Thermistor Switching (Wired Only)
- Ventilation Unit Control (Wired Only)
- Timer Output
- Digital Input/Output Contact - with CZ-TA31P (Optional)

### Comfortability

- Filter Sign
- Hot Start Control

### Field Service & Maintenance

- Indoor Unit Address Setting
- Outdoor Unit Address Setting
- Automatic Address Resetting for Group Control (Wired Only)
- Indoor Unit Test Run Mode
- Emergency Operation (Infrared Only)
- Self Diagnosis Function
- Self Diagnosis Records (Wired Only)

\*Wired: Wired Remote Controller / Infrared: Infrared Remote Controller For more detail, see the feature comparisons of P34-35

\*\*Noise levels are for rear return air only, bottom return air setting may increase noise slightly

Rating Conditions	Cooling	Heating
Inside air temperature	27°C DB/19°C WB	20°C DB
Outside air temperature	35°C DB/24°C WB	7°C DB/6°C WB



# Duct Type

(Mid Static Pressure Type)



## Offers Maximum Installation Flexibility with Slim, Lightweight Design

### Compact, Lightweight Design for Easy Installation

Thin and only 250mm\* high, with a slim width. This compact unit fits easily in limited spaces. The lightweight and small size also make it easier to transport and install.

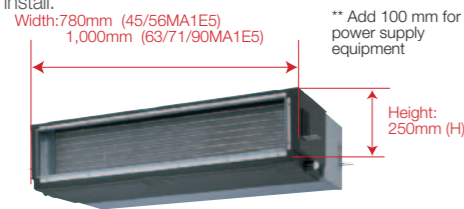

### 3-Way Removable Air Filter

The air filter can be slide in-out in three directions even after duct installation for easier maintenance.

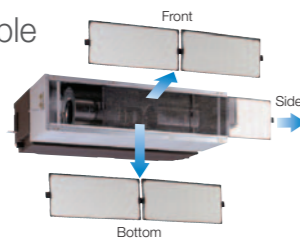

### Versatile Air Inlet and Drain Installation

The mounting locations for the air inlet and drain outlet can be changed as desired for easy, flexible system layout and installation.

### Static Pressure Selection

The static pressure is selectable from 5 or 7 mmAq (49/69 Pa) according to the condition of the duct. For short ducts, the lower pressure of 5 mmAq provides efficient operation.

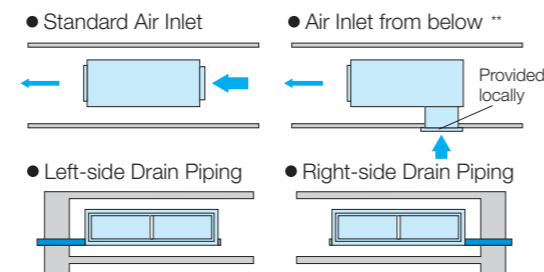

## Features

### Control Flexibility

- 24-Hours ON/OFF Real Setting Timer
- Weekly Timer (Wired Only)
- Group Control by Single Remote Controller
- Outdoor Unit Silent Operation Mode
- Indoor Unit Thermistor Switching (Wired Only)
- Ventilation Unit Control (Wired Only)
- Timer Output
- Digital Input/Output Contact - with CZ-TA31P (Optional)

### Comfortability

- Filter Sign
- Hot Start Control
- Filter

### Field Service & Maintenance

- Indoor Unit Address Setting
- Outdoor Unit Address Setting
- Automatic Address Resetting for Group Control (Wired Only)
- Indoor Unit Test Run Mode
- Emergency Operation (Infrared Only)
- Self Diagnosis Function
- Self Diagnosis Records (Wired Only)

\*Wired: Wired Remote Controller / Infrared: Infrared Remote Controller  
For more detail, see the feature comparisons of P34-35

\*\*Noise levels are for rear return air only, bottom return air setting may increase noise slightly

## Dimensions

S-45MA1E5/ S-56MA1E5

(unit: mm)

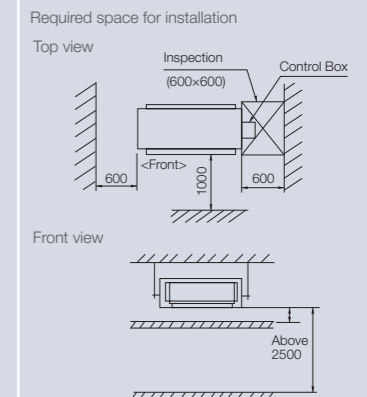
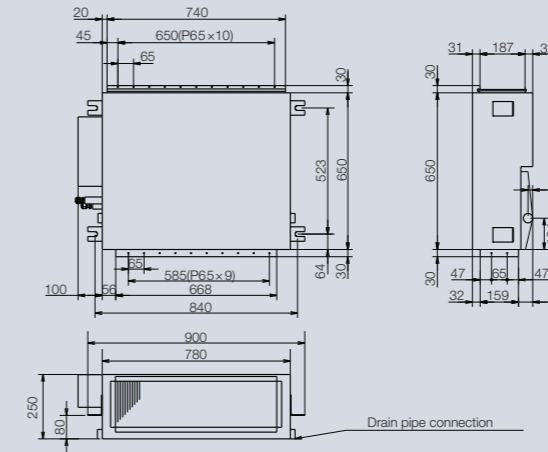

S-63MA1E5/ S-71MA1E5/ S-90MA1E5

(unit: mm)

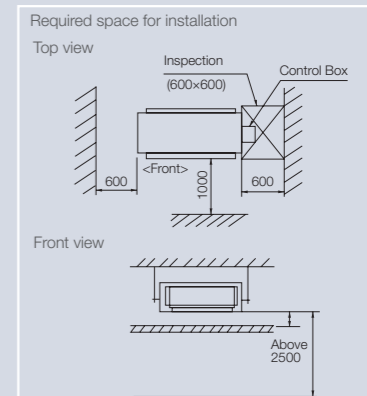
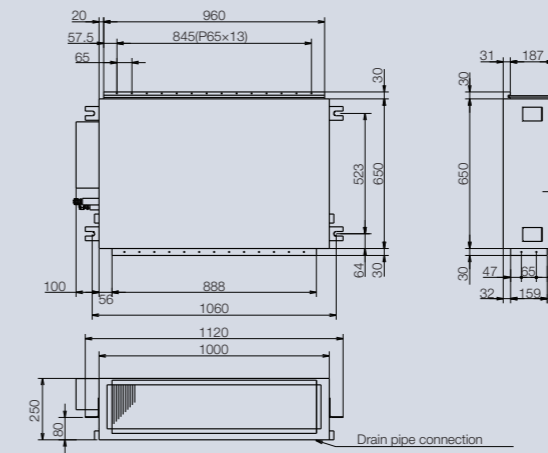

## Specification

		4.5kW	5.6kW	6.3kW	7.1kW	9.0kW	
		S-45MA1E5	S-56MA1E5	S-63MA1E5	S-71MA1E5	S-90MA1E5	
Indoor	Power (kW)						
	Power Source	phase 1φ	1φ	1φ	1φ	1φ	
	V	240	240	240	240	240	
	Hz	50Hz	50Hz	50Hz	50Hz	50Hz	
Cooling	Capacity	kW [Btu/h]	4.50 [15,400]	5.60 [19,100]	6.30 [21,500]	7.10 [24,200]	9.00 [30,700]
	Power Input	W	145	145	145	145	185
	Current	A	0.65	0.65	0.65	0.65	0.85
	Air Volume	Hi Litre/s	250	250	283	283	317
	Sound Pressure Level**	Hi/Lo dB [A]	42/36	42/36	43/37	43/37	44/38
	Sound Power Level**	Hi/Lo dB	57/51	57/51	58/52	58/52	59/53
Heating	Capacity	kW [Btu/h]	5.10 [17,400]	6.40 [21,800]	7.10 [24,200]	8.00 [27,300]	10.00 [34,100]
	Power Input	W	145	145	145	145	185
	Current	A	0.65	0.65	0.65	0.65	0.85
	Air Volume	Hi Litre/s	250	250	283	283	317
	Sound Pressure Level**	Hi/Lo dB [A]	42/36	42/36	43/37	43/37	44/38
	Sound Power Level**	Hi/Lo dB	57/51	57/51	58/52	58/52	59/53
Moisture Removal Volume	L/h [Pt/h]	2.5 [5.3]	3.2 [6.7]	3.6 [7.6]	4.2 [8.8]	5.4 [11.3]	
External Static Pressure * 1	Pa [mmAq]	49/69 [5/7]	49/69 [5/7]	49/69 [5/7]	49/69 [5/7]	49/69 [5/7]	
Dimensions	HxWxD	mm	250x780(+100)* 2x650	250x780(+100)* 2x650	250x1,000(+100)* 2x650	250x1,000(+100)* 2x650	250x1,000(+100)* 2x650
		inch	9-27/32x30-23/32(+3-15/16)	9-27/32x30-23/32(+3-15/16)	9-27/32x39-3/8(+3-15/16)	9-27/32x39-3/8(+3-15/16)	9-27/32x39-3/8(+3-15/16)
Net Weight		kg [lb]	28 [62]	28 [62]	32 [71]	32 [71]	32 [71]
Piping Connection	Liquid Side	mm [inch]	ø6.35 [1/4]	ø6.35 [1/4]	ø6.35 [1/4]	ø9.52 [3/8]	ø9.52 [3/8]
	Gas Side	mm [inch]	12.7 [1/2]	12.7 [1/2]	12.7 [1/2]	15.88 [5/8]	15.88 [5/8]





\*1 The external static pressure is set to 49pa at factory default setting. \*2 Add 100mm for piping port. \*\*Noise levels are for rear return air only, bottom return air setting may increase noise slightly.

Rating Conditions	Cooling	Heating
Inside air temperature	27°C DB/19°C WB	20°C DB
Outside air temperature	35°C DB/24°C WB	7°C DB/6°C WB

# FS MULTI

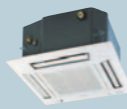
## Feature Comparison

### Indoor Unit

Feature	Model	Wall Mounted		60X60 Cassette		Cassette		Duct (Mid Static Pressure)		Duct (Low Static Pressure)	
	Indoor Unit										
	Remote Controller	Wired Remote Controller	Infrared Remote Controller	Wired Remote Controller	Infrared Remote Controller	Wired Remote Controller	Infrared Remote Controller	Wired Remote Controller	Infrared Remote Controller	Wired Remote Controller	Infrared Remote Controller
Control Flexibility	24-Hours ON/OFF Real Setting Timer	●	●	●	●	●	●	●	●	●	●
	Weekly Timer (6-Pattern/Max. 42-Pattern with Temp Setting)	●	—	●	—	●	—	●	—	●	—
	Group Control by Single Remote Controller	●	●	●	●	●	●	●	●	●	●
	Outdoor Unit Silent Operation Mode (3-Level)	●	●	●	●	●	●	●	●	●	●
	Indoor Unit Thermistor Switching (Indoor Unit or RC)	●	—	●	—	●	—	●	—	●	—
	Ventilation Unit Control	—	—	●	—	●	—	●	—	●	—
	Timer Output	●	—	●	—	●	—	●	—	●	—
Digital Input/Output Contact	—	—	with CZ-TA31P		with CZ-TA31P		with CZ-TA31P		with CZ-TA31P		
Comfortability	Filter Sign	●	●	●	●	●	●	●	●	●	●
	Mildew-Proofing Drain Pan	—	—	●	—	●	—	●	—	●	—
	Hot Start Control	●	—	●	—	●	—	●	—	●	—
	Filter	●	—	●	—	●	—	●	—	●	—
	Super alleru-buster filter	CZ-SA16P (10 years)		CZ-SA13P (3 years)		—		—		—	
Field Service& Maintenance	Indoor Unit Address Setting	●	●	●	●	●	●	●	●	●	●
	Outdoor Unit Address Setting	●	●	●	●	●	●	●	●	●	●
	Automatic Address Resetting for Group Control	●	—	●	—	●	—	●	—	●	—
	Indoor Unit Test Run Mode	●	●	●	●	●	●	●	●	●	●
	Emergency Operation	—	●	—	●	—	●	—	●	—	●
	Self Diagnosis Function	●	●	●	●	●	●	●	●	●	●
	Self Diagnosis Records	●	—	●	—	●	—	●	—	●	—

### Outdoor Unit

Control Flexibility	"Cooling Only" Model Setting (Locked)	●
	Power Save Mode	●
	Outdoor Unit Silent Operation Mode (3-Level)	●
	Auto Restart	●
Field Service& Maintenance	Pump Down Operation	●
	Cooling Operation TESTRUN	●
	Heating Operation TESTRUN	●
	Automatic Address Resetting	●
	Self Diagnosis Function	●(LED display)
Digital Input/Output	Cooling/Heating Selector	●
	Demand Control Input (LV1/LV2/LV3) *	●
	Forced Stop Input	●

\* Panasonic proprietary feature only, not designed to meet or comply with AS4755.3



## 'eco ideas' for Lifestyles

We will promote lifestyles with virtually zero CO<sub>2</sub> emissions all throughout the world

## 'eco ideas' for Business-styles

We will create and pursue a business-style which makes the best use of resources and energy

eco  
ideas

### Quality Management System Certificate



Certified to ISO 9001:2008  
Cert. No.: MY-AR 1010



Certified to ISO 9001:2008  
Registration Number: 01209Q20645R5L

### Certified to ISO 9001: 2008

Panasonic HA Air-Conditioning (M)  
Sdn.Bhd.  
Cert. No.: MY-AR 1010

### Certified to ISO 9001: 2008

Panasonic Home Appliances  
Air-Conditioning (Guangzhou) Co., Ltd.  
Registration Number: 01209Q20645R5L

### Environmental Management System Certificate



Certified to ISO 14001: 2004  
Cert. No.: MY-ER 0112



Certified to ISO 14001: 2004  
Registration Number: 02107E10411R3L

### Certified to ISO 14001: 2004

Panasonic HA Air-Conditioning (M) Sdn.Bhd.  
Cert. No.: MY-ER 0112

### Certified to ISO 14001: 2004

Panasonic Home Appliances  
Air-Conditioning (Guangzhou) Co., Ltd.  
Registration Number: 02107E10411R3L

- Specifications are subject to change without notice for further improvement.
- The contents of this catalog are effective as of March, 2010.
- Due to printing considerations, the actual colors may vary slightly from those shown.

# Panasonic

Panasonic New Zealand Limited  
350 Te Irirangi Drive, East Tamaki  
Manukau 2013, New Zealand  
Telephone: 9 272 0100, Facsimile: 9 272 0134  
panasonic.co.nz

Local Dealer